

LANDOLL CORPORATION, Drexel Division  
 1900 North Street • Marysville, KS 66508  
 Phone: 785-562-5381 • Fax: 785-562-4853  
 www.landoll.com

### STANDARD FEATURES

- Three-wheel configuration
- Rear-wheel drive and steering
- High visibility mast, 3 or 4 stage
- 90° pivoting and shifting mast
- 36 volt electrical system
- Dual joystick control levers
- Adjustable driver's seat
- Safety seat switch - cuts power
- Seat belts
- Parking brake, hand actuated
- Hydraulic service brakes
- GE SX transistor control, with self-diagnostics, hour meter and battery discharge indicator
- GE SR transistor pump control with lift interrupt
- Type "E" construction
- Hydraulic power steering
- Automatic return-to-neutral
- SB350 gray battery connector
- Key switch
- Covered battery compartment
- Battery compartment rollers
- Cushion rubber drive tire (1)
- Polyurethane load tires (2)
- Horizontal fork indicator
- Overhead guard
- Load backrest
- Horn

### OPTIONAL FEATURES

- Strobe warning light
- Flashing backup light in amber, red, yellow or blue
- Headlights, mast or overhead guard mounted
- Tail/stop lights
- Backup alarm
- Type "EE" construction
- Drexel Hi-Low freezer package
- Roller guidance
- Electronic wire guidance
- Low profile overhead guard
- Single auxiliary hydraulics
- Fire extinguisher



### RECOMMENDED BATTERY SPECIFICATIONS

Battery Type	Volts	Amp. Hours	Nominal Size
Flooded or sealed	36V	800	36-7/16" x 21" x 25-3/4" (93 x 53 x 65cm)

- Dealer will select battery size based on the application.
- Usage hours will vary with load weight, number of lift cycles, lift height, attachment use and travel distance.
- Battery compartment inside dimensions – 38-5/8" x 21-3/4" x 27" (98 x 55 x 69cm)
- Battery model 18-100-17, with SB 350 connector – gray for 36V; 36" (91cm) leads; type 2/0 flexible cable; weight: 2,100 lbs. (953kg) minimum; 2,550 lbs. (1,157kg) maximum

The specifications contained in this brochure are subject to change at anytime without notice. Actual dimensions and performance data given herein may vary due to manufacturing tolerances. If any specification is critical to your application, please contact your Landoll/Drexel Dealer.

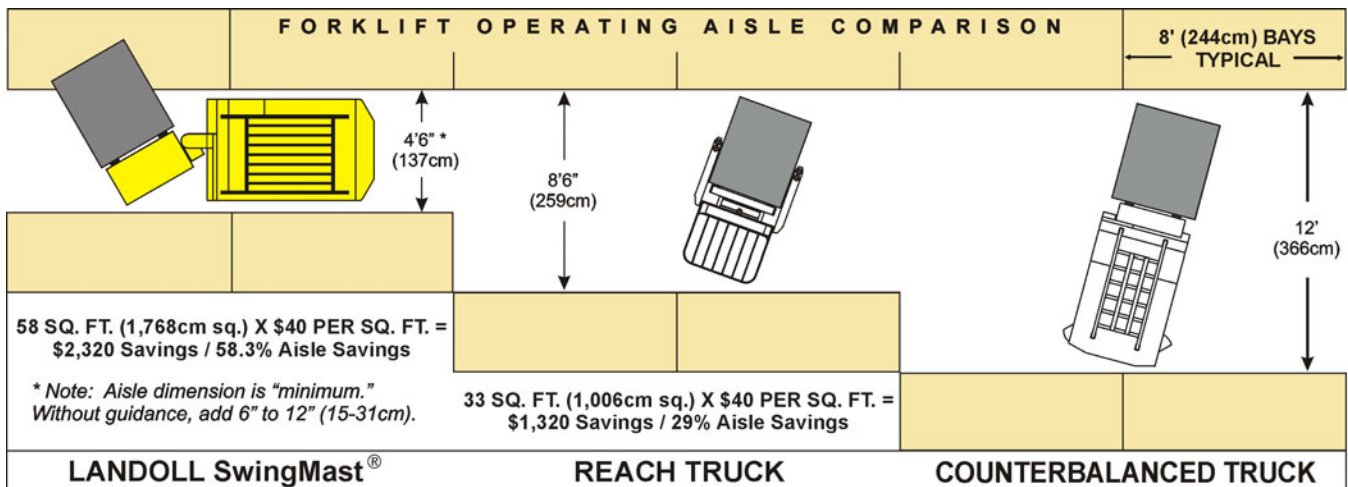

VERY NARROW AISLE FORKLIFT



**DREXEL** Division

# SPECIFICATIONS

**SLT-30/35** SwingMast® Lift Truck  
3,000 and 3,500 lb. Capacity

## DIMENSIONS

<b>TRUCK</b>	<b>SLT30/35</b>	<b>E</b>	<b>F</b>	<b>G</b>	<b>H</b>	<b>I</b>	<b>J</b>	<b>K</b>	<b>L</b>	<b>M</b>	<b>N</b>	<b>O</b>	<b>P</b>	<b>Q</b>	<b>R</b>	<b>S</b>	<b>T</b>	<b>U</b>	<b>V</b>
	IN.	21	57	10	88	3.5	40	88	47	29	20	3	19°	14°	36	48	67	10	45
	CM.	54	143	26	224	9	102	224	118	74	51	8			90	122	170	241	114

<b>SPECIFICATIONS</b>	GRADEABILITY	LOADED	SLT30	SLT35	MAST TILT	DEGREES	SLT30	SLT35
	CAPACITY AT 24" L/C	LBS.	3,000	3,500	POLY LOAD TIRES (2)	IN.	16.2" x 10" x 11.2"	
		KG.	1,361	1,588		CM.	41 x 25 x 29	
	FORK SIZE (Standard)	IN.	1.5" x 4" x 40"		VOLTAGE		36	
	ITA CLASS II	CM.	3.8 x 10.0 x 102		LOWERING SPEED	EMPTY	60 FPM/18 MPM	
	LIFT SPEED	LOADED	65 FPM/20 MPM			LOADED	80 FPM/24 MPM	
	TRUCK WEIGHT, with BATTERY (Minimum)	LBS.	11,050	11,650	TRAVEL SPEED	EMPTY	6 MPH/9.65 KPH	
		KG.	5,012	5,284		LOADED	5.6 MPH/9 KPH	
CUSHION RUBBER DRIVE TIRE (1)	IN.	18" x 7" x 12.1"		MINIMUM BATTERY WEIGHT	LBS.	2,100		
	CM.	46 x 18 x 31			KG.	954		

MAST TYPE	A		B		C		D	
	MAX. FORK HEIGHT (IN.) (CM.)	COLLAPSED HEIGHT (IN.) (CM.)	FREE LIFT HEIGHT (IN.) (CM.)	MAX. OVERALL HEIGHT (IN.) (CM.)	MAX. FORK HEIGHT (IN.) (CM.)	COLLAPSED HEIGHT (IN.) (CM.)	FREE LIFT HEIGHT (IN.) (CM.)	MAX. OVERALL HEIGHT (IN.) (CM.)
TRIPLE	170	432	77	196	51	130	218	554
TRIPLE	198	503	87	221	61	155	246	625
TRIPLE	205	521	90	229	64	163	253	643
TRIPLE	215	546	94	239	68	173	263	668
TRIPLE	226	574	101	257	75	191	274	696
TRIPLE	242	615	107	272	81	206	290	737
TRIPLE	250	635	113	287	87	221	298	767
TRIPLE	269	683	120	305	99	251	317	805
QUAD	240	610	84	213	63	160	288	732
QUAD	258	655	89	226	67	170	306	727
QUAD	268	681	91	231	70	178	316	803

ABOVE DIMENSIONS ARE BASED ON A 3" (7.6cm) MAST UNDERCLEARANCE.



CERTIFIED ISO 9001:2000

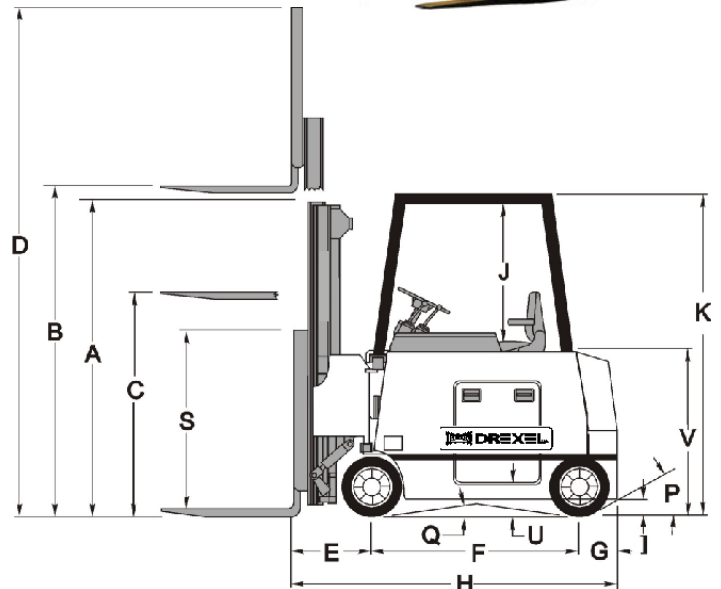
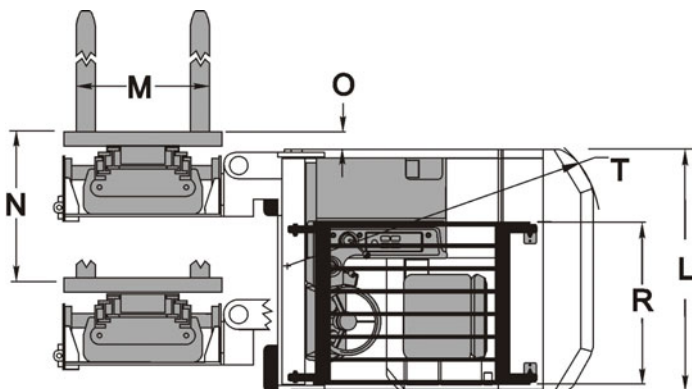

VERY NARROW AISLE FORKLIFT