

LANDOLL CORPORATION, Drexel Division
 1900 North Street • Marysville, KS 66508
 Phone: 785-562-5381 • Fax: 785-562-4853
 www.landoll.com

STANDARD FEATURES

- Three-wheel configuration
- Rear-wheel drive and steering
- High visibility mast, 3 or 4 stage, with silent staging
- 90° pivoting and shifting mast
- 48 volt electrical system
- Dual joystick control levers
- Adjustable driver's seat
- Safety seat switch - cuts power
- Seat belts
- Parking brake, hand actuated
- Hydraulic service brakes
- GE SX transistor control, with self-diagnostics, hour meter and battery discharge indicator
- GE SR transistor pump control with lift interrupt
- Type "E" construction
- Hydraulic power steering
- Automatic return-to-neutral
- SB350 blue battery connector
- Covered battery compartment
- Battery compartment rollers
- Polyurethane drive tire (1)
- Polyurethane load tires (2)
- Horizontal fork indicator
- Overhead guard
- Load backrest
- Key switch
- Horn

OPTIONAL FEATURES

- Strobe warning light
- Flashing backup light in amber, red, yellow or blue
- Headlights, mast or overhead guard mounted
- Tail/stop lights
- Backup alarm
- Type "EE" construction
- Drexel Hi-Low freezer package
- Roller guidance
- Electronic wire guidance
- Low profile overhead guard
- Single auxiliary hydraulics
- Fire extinguisher



RECOMMENDED BATTERY SPECIFICATIONS

Battery Type	Volts	Amp. Hours	Nominal Size
Flooded or sealed	48V	up to 700	38" x 26" x 26" (97 x 66 x 66 cm)

- Dealer will select battery size based on the application.
- Usage hours will vary with load weight, number of lift cycles, lift height, attachment use and travel distance.
- Battery compartment inside dimensions – 38-5/8" x 26-1/2" x 27" (98 x 67 x 69 cm)
- Battery model 24-85 (or 100)-15, with SB 350 connector – blue for 48V; 36" (91cm) leads; type 2/0 flexible cable; weight: 2,650 lbs. (1,202kg) minimum; 2,850 lbs. (1,293kg) maximum

The specifications contained in this brochure are subject to change at anytime without notice. Actual dimensions and performance data given herein may vary due to manufacturing tolerances. If any specification is critical to your application, please contact your Landoll/Drexel Dealer.

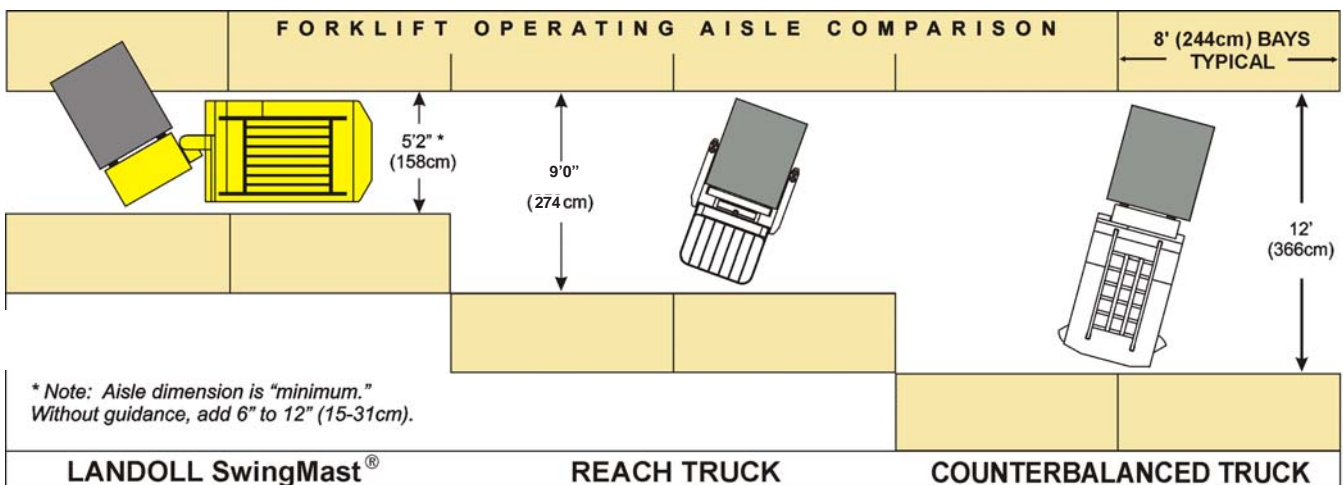

VERY NARROW AISLE FORKLIFT



DREXEL Division

SPECIFICATIONS

SLT-35-HLC SwingMast® Lift Truck
3,500 lb. Capacity

DIMENSIONS

TRUCK	SLT35-HLC	E	F	G	H	I	J	K	L	M	N	O	P	Q	R	S	T	U	V
	IN.	21	61	10	92	4.6	40	88	55	31	26	3	19°	14°	36	48	73	10	45
	CM.	54	154	26	234	12	102	224	139	79	66	8			90	122	186	241	114

SPECIFICATIONS	GRADEABILITY	LOADED	10%	MAST TILT	DEGREES	3° FWD./4° BACK
	CAPACITY AT 24" L/C	LBS.	3,500	POLY LOAD TIRES (2)	IN.	16.2" x 10" x 11.2"
		KG.	1,588		CM.	41 x 25 x 29
	FORK SIZE (Standard)	IN.	1.5" x 4" x 40"	VOLTAGE		48
	ITA CLASS II	CM.	3.8 x 10.0 x 102			
	LIFT SPEED (36 Volt)	EMPTY	90 FPM/27 MPM	LOWERING SPEED	EMPTY	60 FPM/18 MPM
		LOADED	65 FPM/20 MPM		LOADED	80 FPM/24 MPM
TRUCK WEIGHT, with BATTERY (Minimum)	LBS.	12,500	TRAVEL SPEED	EMPTY	7.2 MPH/11.6 KPH	
	KG.	5,670		LOADED	7.0 MPH/11.3 KPH	
POLY DRIVE TIRE (1)	IN.	18" x 7" x 12.1"	MINIMUM BATTERY WEIGHT	LBS.	2,650	
	CM.	46 x 18 x 31		KG.	1,202	

MAST TYPE	A MAX. FORK HEIGHT		B COLLAPSED HEIGHT		C FREE LIFT HEIGHT		D MAX. OVERALL HEIGHT	
	(IN.)	(CM.)	(IN.)	(CM.)	(IN.)	(CM.)	(IN.)	(CM.)
TRIPLE	198	503	87	221	63	160	246	625
TRIPLE	205	521	90	229	64	163	253	643
TRIPLE	216	549	95	241	69	173	264	671
TRIPLE	234	594	103	262	77	196	282	716
TRIPLE	250	635	111	282	85	216	298	757
TRIPLE	266	676	119	302	93	236	314	798
TRIPLE	284	721	125	318	99	252	332	843
TRIPLE	302	727	131	332	105	267	350	889
QUAD	Contact Factory		Contact Factory		Contact Factory		Contact Factory	

ABOVE DIMENSIONS ARE BASED ON A 3" (7.6cm) MAST UNDERCLEARANCE.

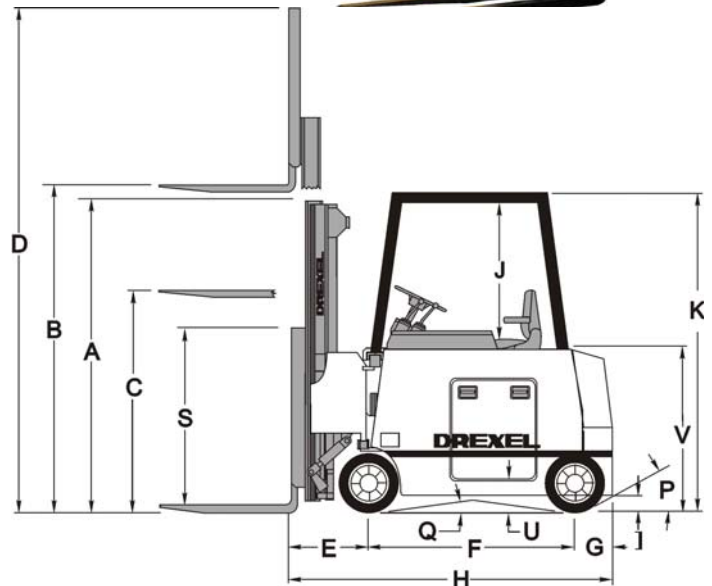
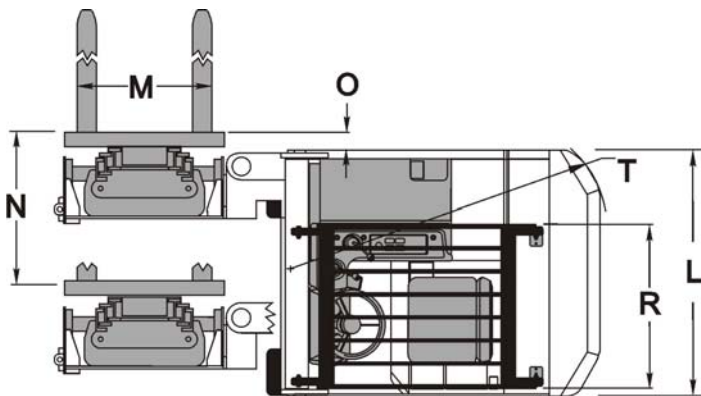

VERY NARROW AISLE FORKLIFT